

# 19C Series 0 to 3psi to 0 to 500psi

Low Cost, Stainless Steel Isolated Pressure Sensors



## General Description

The stainless steel 19C Series devices were developed for pressure applications that involve measurement of hostile media in harsh environments. These sensors will accommodate any media that will not adversely attack 316 stainless steel.

These 19mm sensors are available for use with either a constant voltage or current source. They feature a variety of pressure connections to allow use in a wide range of OEM equipment.

The 19C Series devices are rugged and reliable transducers for use in a wide variety of pressure sensing applications where corrosive liquids or gases are monitored. Contact your local Invensys representative or the Invensys factory for additional details.

## Features

### Reliable Semiconductor Technology

- Calibrated and Temperature Compensated
- Isolated
- Rugged--Stainless Steel Package
- Small Size
- Absolute & Gage Pressures
- Reliable Semiconductor Technology

## Applications

- Industrial Controls

## Equivalent Circuit

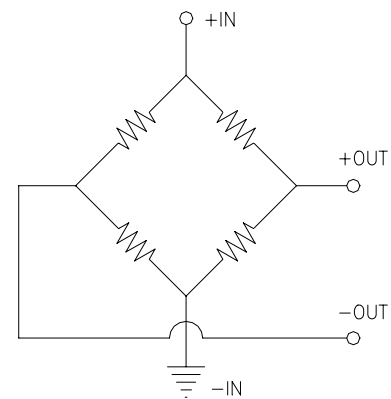

## Ordering Information - Part # Description

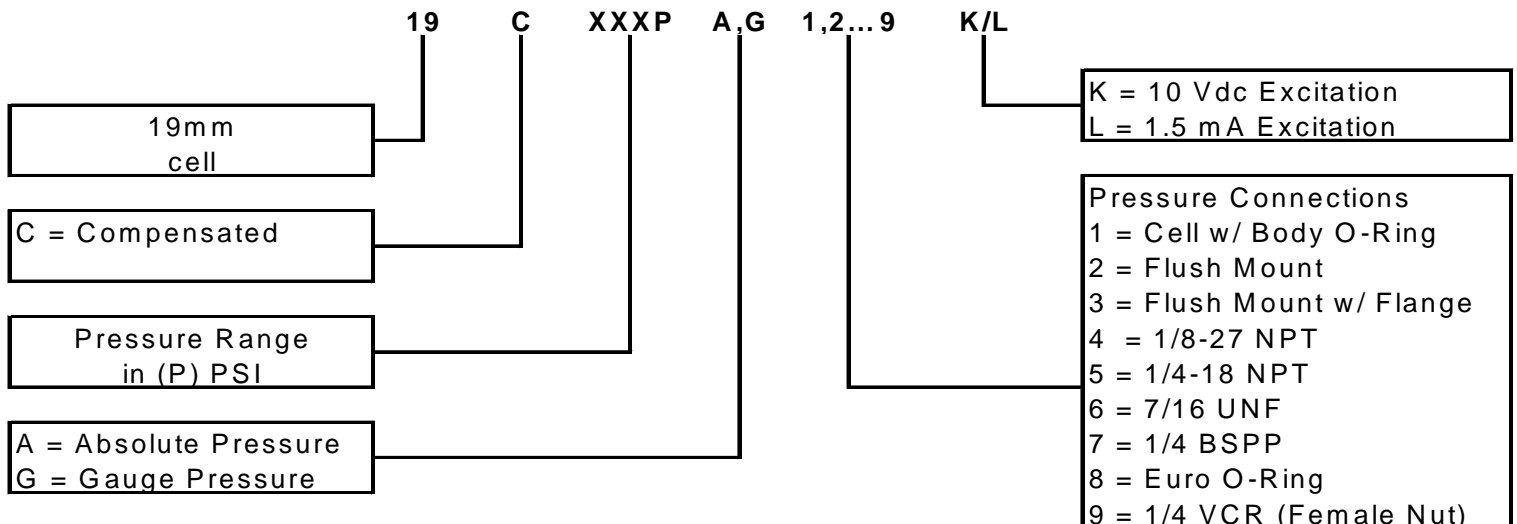

For example: Part #19C100PA4K = 19 mm Cell, Compensated, 100 psi, Absolute, 1/8NPT Port, with 10 Vdc excitation.

**Pressure Sensor Characteristics (all devices)****Environmental Specifications**

Compensated: 0°C to +82°C

Operating: -40°C to +125°C

Storage: -40°C to +125°C

Vibration: 10G at 20-2000 Hz

Shock: 100G for 11 msec

Life: 1 Million cycles minimum

Insulation Resistance 100MΩ at 50 Vdc

**Maximum Ratings (all devices)**Voltage Version "K": Supply Voltage  $V_S = +15$  VdcCurrent Version "L": Supply Current  $I_S = +2.0$  mA**Pressure Range Specifications**

SenSym/ICT PART # *	PRESSURE RANGE	PROOF PRESSURE (7)	BURST PRESSURE (8)
19C 003P G (1...9) (K/L)	0-3 psig	9 psig	15 psig
19C 005P G (1...9) (K/L)	0-5 psig	15 psig	25 psig
19C 010P G (1...9) (K/L)	0-10 psig	30 psig	30 psig
19C 015P (A/G) (1...9) (K/L)	0-15 psi	45 psi	75 psi
19C 030P (A/G) (1...9) (K/L)	0-30 psi	90 psi	150 psi
19C 050P (A/G) (1...9) (K/L)	0-50 psi	150 psi	250 psi
19C 100P (A/G) (1...9) (K/L)	0-100 psi	300 psi	500 psi
19C 200P (A/G) (1...9) (K/L)	0-200 psi	600 psi	1000 psi
19C 300P (A/G) (1...9) (K/L)	0-300 psi	900 psi	1500 psi
19C 500P (A/G) (1...9) (K/L)	0-500 psi	1200 psi	2400 psi

\* Note: Parts are available in Absolute and Gauge pressure (A=Absolute, G=Gauge) and in a variety of ports (1 thru 9).

Performance Characteristics <sup>(1)</sup>

Characteristic	Min	Typical	Max	Units
Zero pressure offset	-2	0	+2	mV
Full scale span <sup>(2)</sup>	98	100	102	mV
Full scale span (3 and 5 psi "K" units only) <sup>(2)</sup>	48	50	52	mV
Nonlinearity <sup>(3)</sup>	--	±0.1	±0.25	%FSS
Pressure hysteresis <sup>(3)</sup>	--	±0.015	±0.030	%FSS
Repeatability	--	±0.010	±0.030	%FSS
Temp. effect on span <sup>(4)</sup>	--	±0.5	±1.0	%FSS
Temp. effect on offset <sup>(4)</sup>	--	±0.5	±1.0	%FSS
Temp. effect on span (0-3 and 0-5 psi only) <sup>(4)</sup>	--	--	±2.0	%FSS
Temp. effect on offset (0-3 and 0-5 psi only) <sup>(4)</sup>	--	--	±2.0	%FSS
Thermal hysteresis (0 to 82°C)	--	±0.1	±0.3	%FSS
Long term stability of offset & Span <sup>(5)</sup>	--	±0.1	±0.3	%FSS
Response time (10% to 90%) <sup>(6)</sup>	--	0.1	--	ms
Common Mode Voltage (Voltage Version "K") <sup>(9)</sup>	.50	1.25	2.0	Vdc
Input impedance (Current Version "L")	2.0	4.5	8.0	kΩ
Input impedance (Voltage Version "K")	8.0	25	50	kΩ
Output impedance	3.0	4.5	6.0	kΩ

**Specification Notes:**

- Note 1:** Reference Conditions (unless otherwise noted): Supply,  $V_S=10\text{ Vdc}\pm 0.01\text{ Vdc}$  or  $I_S=1.5\text{ mA}\pm 0.0015\text{ mA}$ ;  $T_a=25^\circ\text{C}$ .
- Note 2:** Span is the algebraic difference between the output voltage at full scale pressure and the output at zero pressure. Full Scale Span (FSS) is ratiometric to the supply voltage.
- Note 3:** Linearity is based on best-fit straight line from the zero to the full scale pressure. Hysteresis is the maximum output difference at any point within the operating pressure range for increasing and decreasing pressure.
- Note 4:** Maximum error band of the offset voltage or span over the compensated temperature range, relative to the 25°C reading.
- Note 5:** Long term stability over a six month period.
- Note 6:** Response time for a step change from the zero pressure to the full scale pressure.
- Note 7:** The maximum pressure that can be applied without changing the transducer's performance or accuracy.
- Note 8:** The maximum pressure that can be applied to a transducer without rupture of either the sensing element or transducer case.
- Note 9:** Common Mode Voltage as measured from output to ground.

Physical Dimensions

Cell Package "1" (See Note 1)

File: SS60150

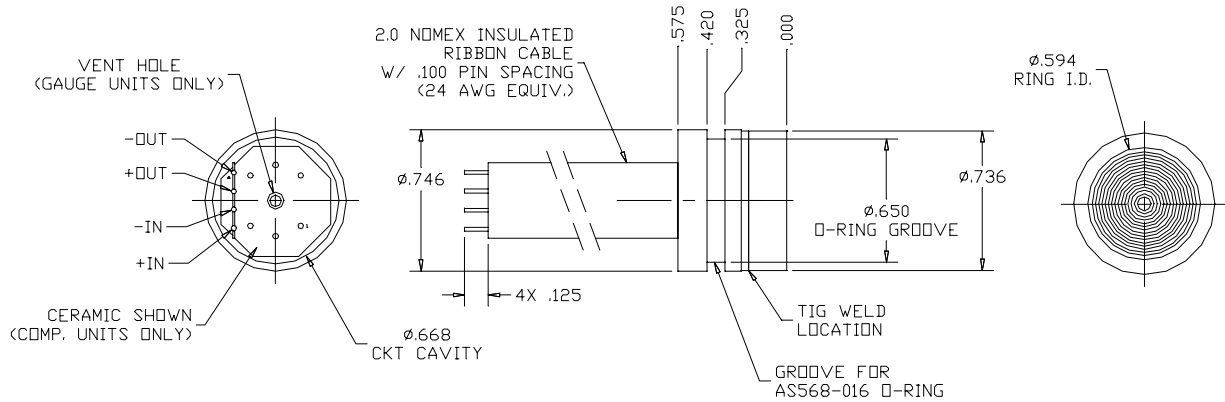

Flush Mount Package "2"

File: SS60151

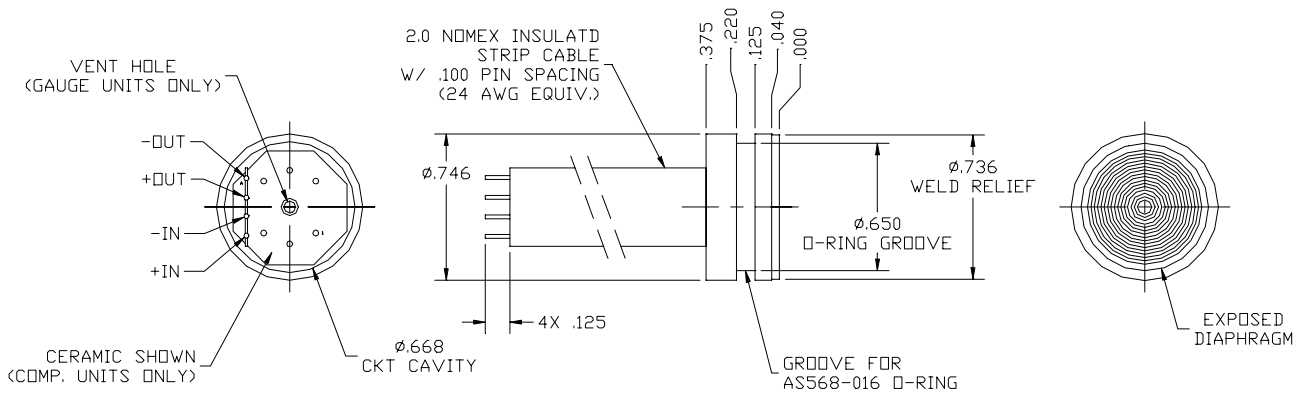

Physical Dimensions

Flush Mount with Flange Package "3"

File: SS60152

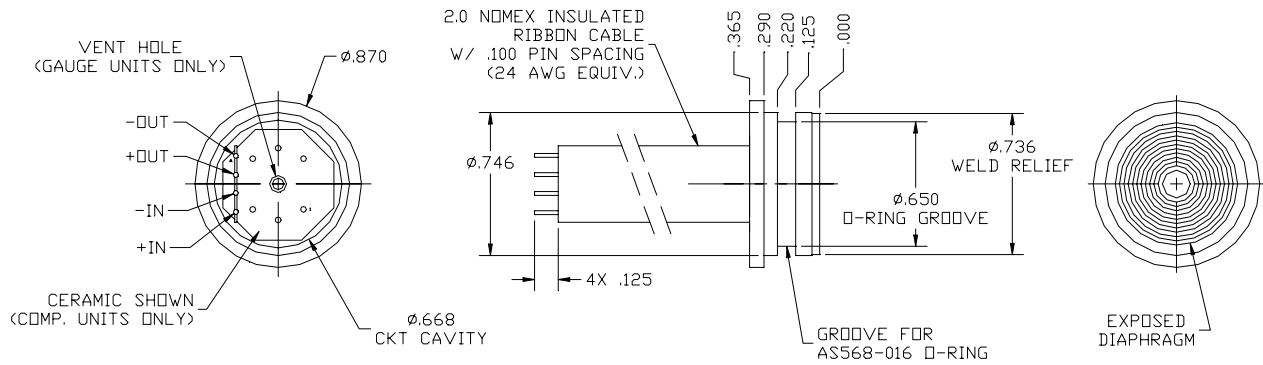

Male 1/8-27 NPT Package "4"

File: SS60153

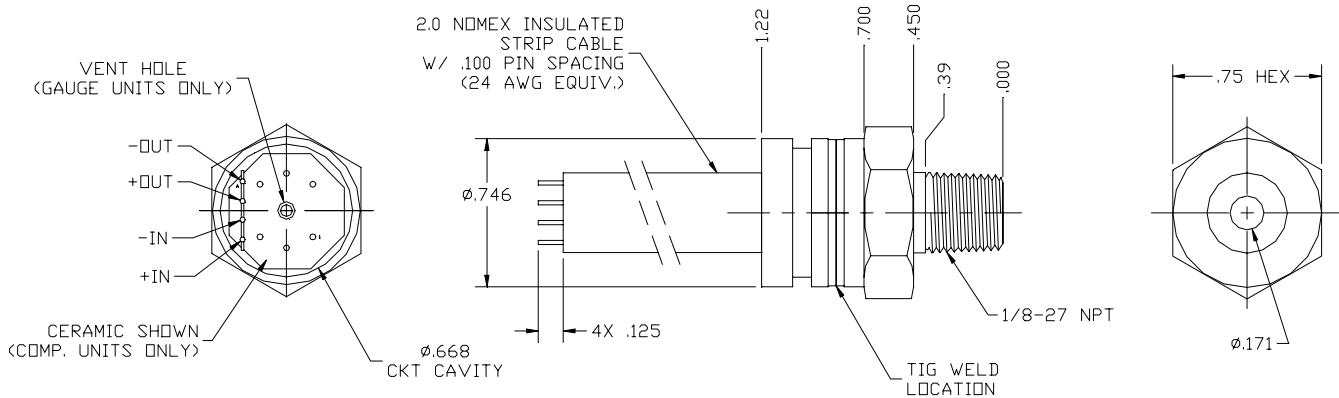

Physical Dimensions

Male 1/4-18 NPT Package "5"

File: SS60154

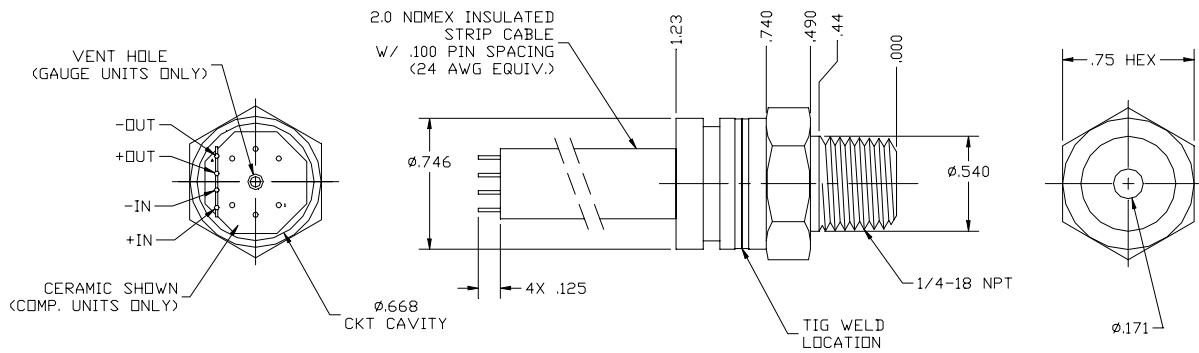

Male 7/16 UNF Package "6"

File: SS60155

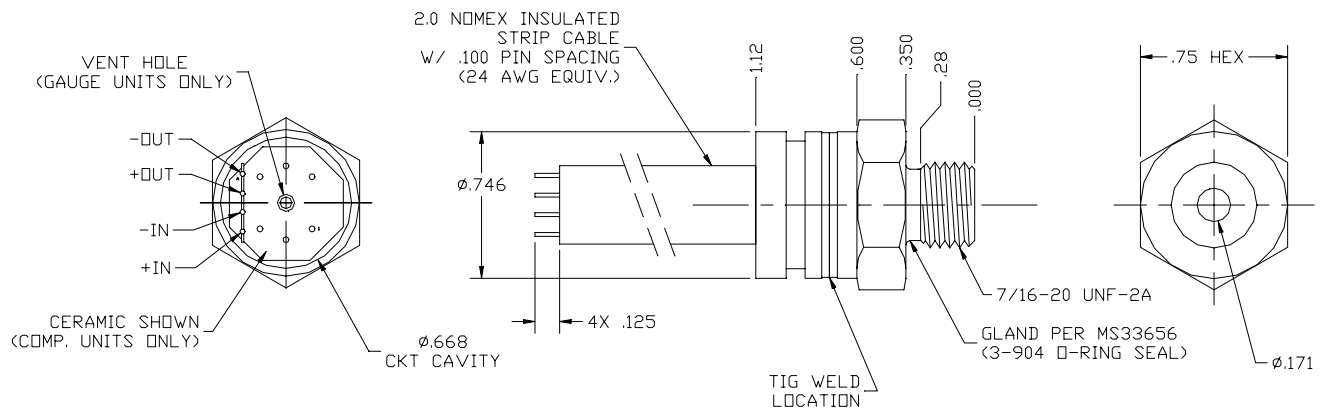

Physical Dimensions

Male 1/4 BSPP Package "7"

File: SS60156

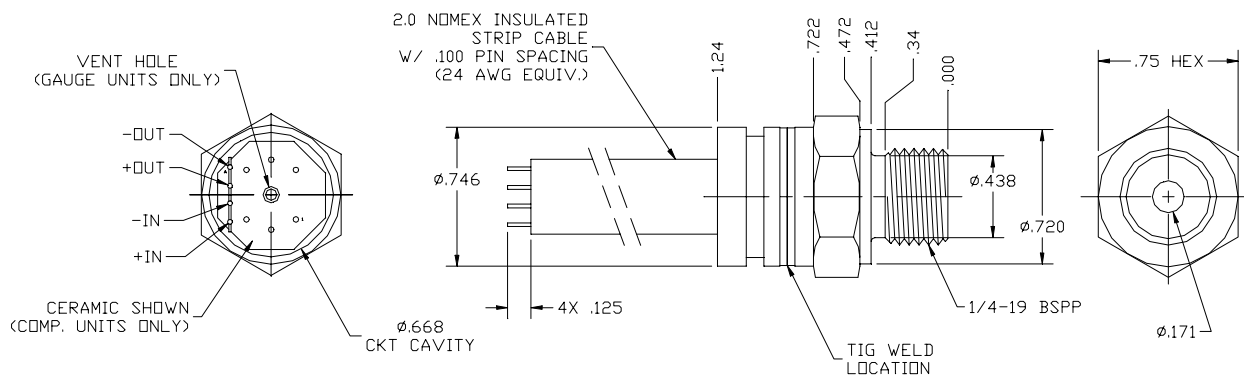

Euro Ring Package "8" (See Note 1)

File: SS60157

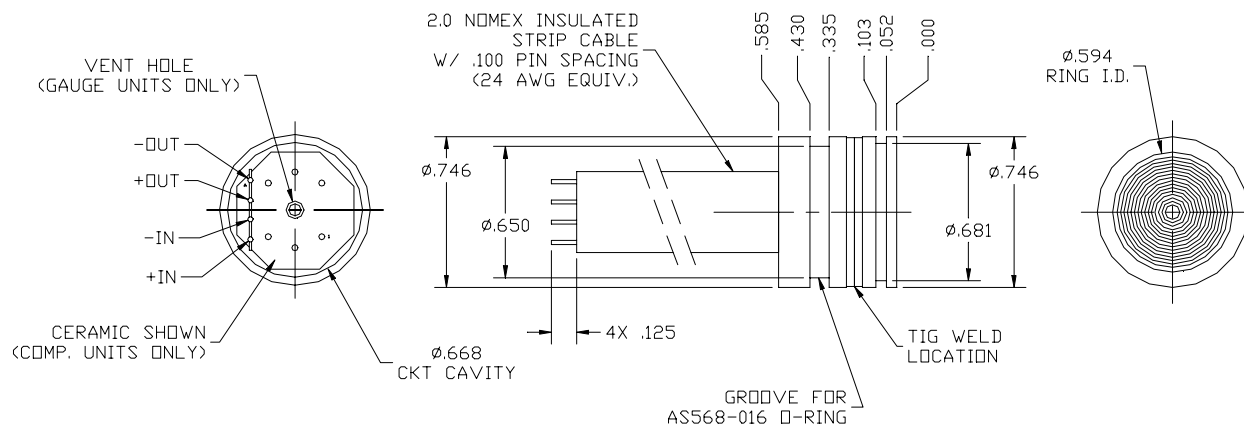

Physical Dimensions

VCR Gland (Female Nut) Package "9"

File: SS60177

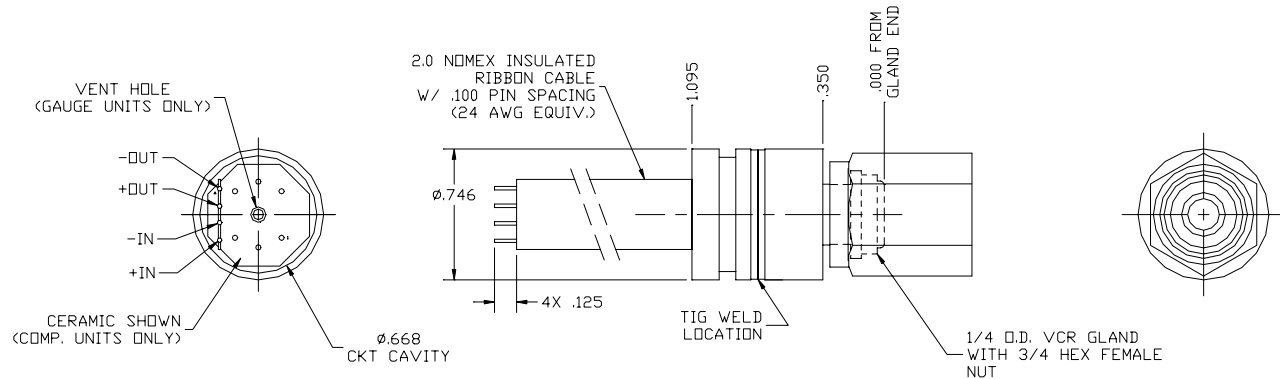

Note1: Non-concentricity effects at the diaphragm weld area may cause run out of up to  $\pm 0.006$ " between the upper and lower portions of the sensor body. (It is recommended to use a counter bore in the mating bore used with this device to allow for this non-concentricity.)

SenSym reserves the right to make changes to any products herein. SenSym does not assume any liability arising out of the application or use of any product or circuit described herein, neither does it convey any license under its patent rights nor the rights of others.